

NON-STOP UNWIND/REWIND TURRET STATIONS

Dynaspede presents **Non-Stop Turret Unwind & Rewind Stations** for continuous roll-to-roll or roll-to-sheet web processing applications. On board intelligent controls ensure on-the-fly lap splicing at full speeds with consistently short splice tails for unwinds and anti-curling for rewind splices.

Commanding features.

Reliable Splicing at full speed... comparable with the best in the world.

Machines are individually featured to match your machine layout.

Specific models for winding /unwinding with print-in or print out.

Automatic tension controls for smooth bump-less roll-to-roll transfer.

Intelligent control synchronizes cutting and pasting operation in unwinders, precisely at the taped end leaving negligible splice tail.

Inertia compensated dancers and frictionless pneumatics to absorb all tension transients during splicing.

Programmable Controllers automatically initiate the splice sequence at pre-selected roll diameters.

Independent DC motors with digital 4-quadrant controls.

Pneumatic fail-safe brakes for the turret and electronic DC injection brakes for the turret motor.

DYNASPEDE AUTOMATIC UNWIND / REWIND TURRET STATIONS SERVE THE NEEDS OF PRINTING, PACKAGING AND CONVERTING INDUSTRIES FOR A COST-EFFECTIVE SPLICING EQUIPMENT WITH POTENTIAL BENEFITS OF REDUCED WASTAGE, INCREASED PRODUCTION, ONE-MAN ROLL CHANGES AND MINIMUM OPERATOR DEPENDENCE.

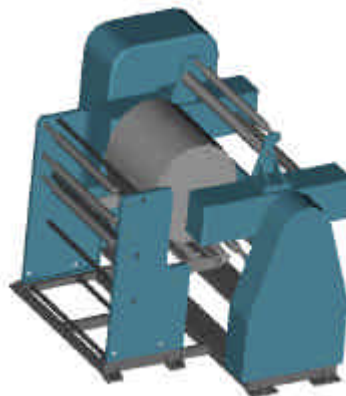

OPTIONS

Built-in in-feed or out-feed Nip rolls.

Edge guiding units.

Customer specified operator side.

Winding either with print side in or print side out.

Variety of core holding options.

Dynaspede Web Products Division is manned by a team of talented professionals propelled by a compelling reason to remain at the leading edge of web control technology... to help you run your machines efficiently... with products that not only promise but deliver the results.

Tension control Products

- ? Magnetic Particle Devices
- ? Pneumatic Brakes & Clutches
- ? Auto Tension Controls
- ? Tension Sensors

Speed control Products.

- ? AC, DC or Eddy current drives
- ? Analogue or Digital multi-drive systems
- ? Single or multi-quadrant operation
- ? PLC or PC based control systems

Web control Products

- ? Web Guiding systems
- ? Corona Treating Stations
- ? Static Eliminating Systems
- ? Safety Chucks
- ? Planetary Gear systems
- ? Unwind & Rewind stands

Customer Support

From pre-sales engineering support through commissioning and after-sales service ...available from our Sales & Service Centres at:

**Delhi - Mumbai - Bangalore
Lucknow - Calcutta - Baroda
Chennai - Hyderabad - Hosur**

OVERALL DIMENSIONS
TURRET UNWINDER
WITH AUTO SPLICE
DIMN IN MM

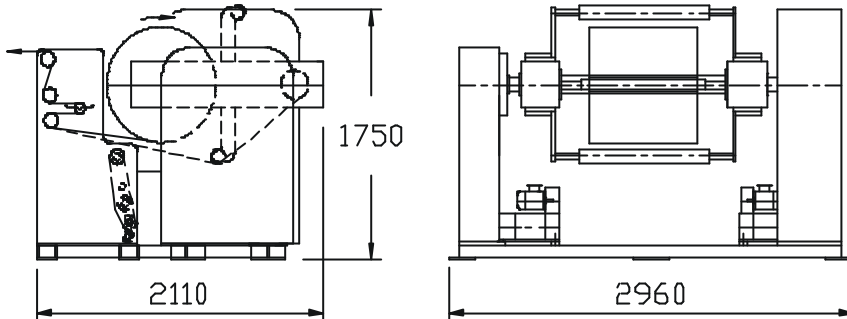

Dancers are designed based on a complex inertia compensation technique of mathematically matching the inertia values of various elements that make up a dancer assembly. Dynaspede dancers demonstrate in full measure, the capabilities of such true dancers pneumatically positioned by low friction cylinders.

Some of the more frequently asked questions.

Machine Construction.

Turret stations are cyclically subjected to high impact loads leading to high stresses especially on the turret arms and supporting members, causing premature failure of machine members in poorly designed machines. Dynaspede design is optimized by computer simulation for detailed stress analysis of critical load bearing members. Box type turret arms, for example is a result of such computer-aided FEM analysis.

Shaft Holding Safety Chucks.

These innocuous looking devices have to withstand high and repeated static and dynamic loads on overhanging rolling bearings. Most parts are subjected to wear each time the roll is loaded or unloaded. Dynaspede Safety Chucks are constructed out of high quality alloy steel, carefully heat treated for wear resistance. Self locking cams are liberally designed for safety of equipment and operating personnel.

Side Lay adjustment.

Hand-wheels are conveniently located on both the turret arms for manual adjustments of roll centering while loading or running conditions.

Splicing mechanism.

This is uniquely designed to ensure reliable splicing under all conditions. Three separate pneumatic cylinders control the positioning, pasting and splicing operations. Knife is actuated by a special high-speed cylinder with over-excitation technique.

Splicing.

Conventional time-based unwind splicing results in uncontrolled splice tail lengths, leading to avoidable web breakage due to machine jamming. Dynaspede splicers for unwinds, are intelligent to actuate precisely by position sensing of the pasted end. This results in minimum and repeatable splice tail lengths.

Similarly, rewind splicers are fitted with a unique anti-curl mechanism to swipe the cut end smoothly over the new roll to avoid fold-back and wrinkle formation.

Tension Changes during splicing.

It is well known that a well designed dancer can fully absorb any tension transient and prevent it from transmitting to the machine side. By the same rule, a poorly designed dancer is worse than no dancer at all.

Bumpless roll transfer.

An independent DC drive predrives the new roll to a speed precisely matching the current surface speed of the expiring roll. Variations in unwind roll diameters are sensed by light switch and accounted for.

Splice Sequencing.

Splice sequencing is automatic and operator independent. Turret positioning at preset diameters, new roll driving up to speed, slicing operation and transfer of control etc. are all automatic with flashing lights and audible alarm with full scope for operator to intervene at will.

If you have more questions, please write to:

Dynaspede Integrated Systems (P) Limited,

136-A, Sipcot Industrial Complex, Hosur - 635 126. (T.N)
Tel. (04344) 276915 (5 Lines); Fax. 91-4344-276841.
e-mail : dynaspede@mailzone.com

- Bangalore
- Baroda
- Calcutta
- Chennai
- Delhi
- Lucknow
- Mumbai
- Secunderabad