

IT 21 SERIES

For UNWIND
INTERMEDIATE
REWIND *Sections*

- ☛ Soft START / STOP control
- ☛ Splice Control
- ☛ 16 job save memory
- ☛ Web break detection
- ☛ Built-in signal conditioner for load cell and speed sensor
- ☛ 0-10V DC output for external tension indicator
- ☛ Configurable analog / digital inputs
- ☛ Optional CAN Bus interface for Tension Tuner *
- ☛ Optional RS-232 interface for PC/Laptop
- ☛ Tension setting by keypad, potentiometer or external reference



IP 20 CE

IT 21 Series is DSP based intelligent tension controller designed for web tension control of unwind, intermediate and rewind sections based on feedback from load cells or dancer or diameter sensors. IT 21 is compact and versatile in nature...same model can be used for the winders and unwinders. The control is achieved in closed loop or in open loop mode, regulating the brake, clutch or drive.

IT 21-DC Dancer based

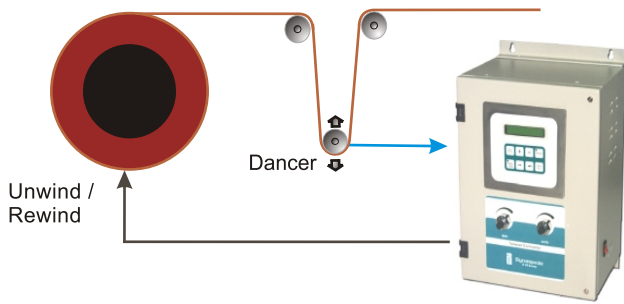

IT 21-LC Load Cell based

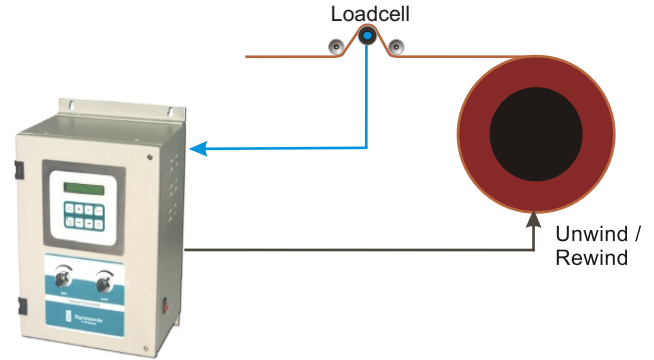

IT 21-RC Diameter based

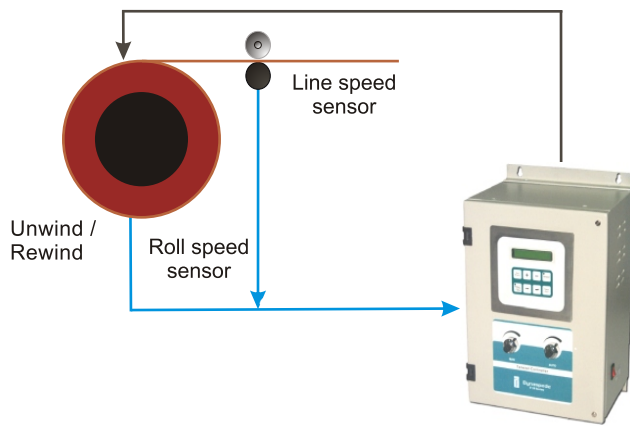

IT 21-SC for intermediate applications

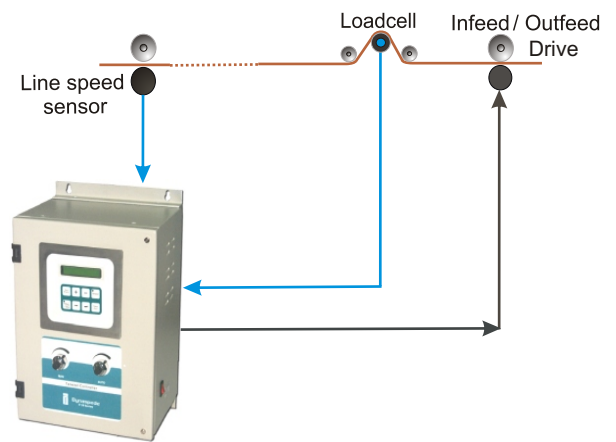

SPECIFICATIONS

- Supply voltage**.....240/120V AC +10%, -20%, 220/110V AC ±10%, 50/60 Hz.
- Internal power supplies**.....3V DC, +15V DC, 5V DC -5V DC & 9V DC
- Supply for potentiometer**.....3V DC ±5, max load - 10mA
- Supply for load-cell**.....10V DC split into ±5V with respect to Ground.
- Voltage tolerance : ±5%. Current rating: 75mA.
- Input signals**
- Load cell1 & Load cell2 : 1.5 to 12 mV at max Tension, Zi of 350 to 1000 ohm
- Proximity switch : 9V DC supply with current rating of 25mA.
- Analog inputs : 4 channel, 0 - 10V DC/ 4-20mA, Zi >= 10k ohm
- Digital inputs : 5 Potential free contacts, rated 24V DC or more / .05Amp or more.
- Output signals**
- Excitation output : 0-24V DC, 5Amp.
- Analogue Outputs : 1) 0 - 10V DC or 4-20mA selectable by jumper
2) 0 - 10V DC outputs, Zo >= 2.2k ohm for voltage outputs & Zo <= 500 ohm for current output
- Digital Output : Open collector Digital output rated 5 VDC, 100 mA
- Indications**
- LCD Display : 2 line X 16 character Display with back light for user interface.
- Keypad : Membrane keypad with 8 keys
- LED : LED indication for Tension ON/OFF and AUTO/MAN modes.

- Ambient**.....40° C
- Altitude**.....Less than 1000 meters
- Enclosure protection**.....Dust & Vermin proof
- Mounting**.....Wall / machine mounting

*Ask for TENSION TUNER catalogue for further details

MECHANICAL DIMENSIONS

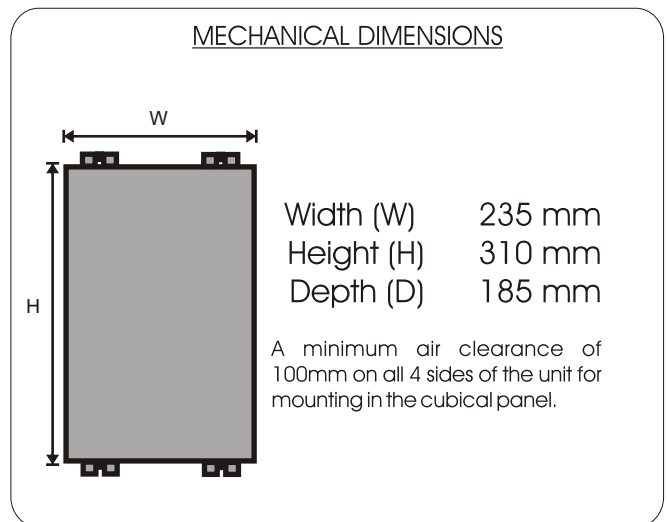

Information subject to change without prior notice



Cat. 2K5 03

DYNASPEDE INTEGRATED SYSTEMS (P) LIMITED
136 A , Sipcot Industrial Complex
HOSUR 635109 (TN), INDIA

TEL : +91 4344 276915
FAX : +91 4344 276841
EMAIL : mail@dynaspede.com
WEB : www.dynaspede.com